

Antenna Analyzer from EU1KY Software Variante DH1AKF



1 Commissioning (basic settings and calibration)

- Insert SD-Card : 1GB minimum, FAT32 format.
- Use **Settings> Calibration> Oscillator Test** (see 6.3.3) to determine the maximum frequency of the SI5351 chip and note the suggested values for SI5351_MAX_FREQ and BAND_FMAX.
- With **Settings> Configuration> Next Param**, set the desired values of the following parameters:
SI5351_MAX_FREQ as determined previously
BAND_FMIN 100...500 kHz
BAND_FMAX as determined previously
Save values with **Save and exit**.
- Set the jumper to the **CAL** position on the adapter PCB.
- Start the hardware calibration with **Settings > Calibration > HW Calibration**.
- On the adapter PCB, reset the jumper to the **WORK** position.
- Start the Open Short-Load Calibration with **Settings> Calibration> OSL Calibration**. To do this, prepare the calibration set (open circuit, short circuit, 50 Ω).
- Oscillator adjustment : Set the frequency to 27,000 MHz with the **Generator** and measure the frequency with the frequency counter or receiver. With **Settings> Configuration** with **Next Param**, select parameter **SI5351_CORR** and enter the previously measured **Deviation** in Hertz.

2 Main Menu

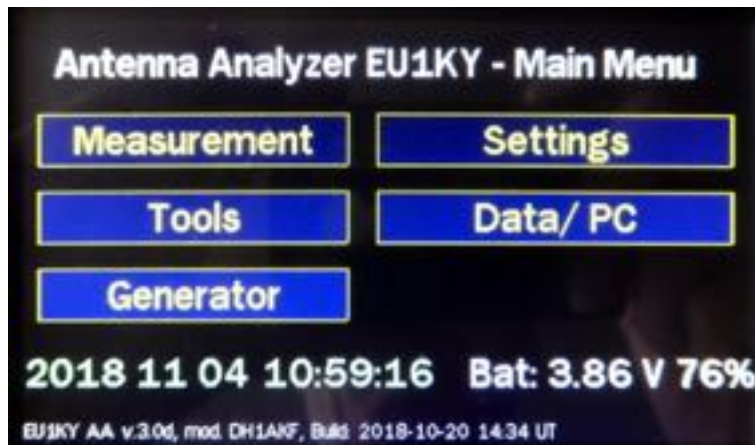

3 Measurement

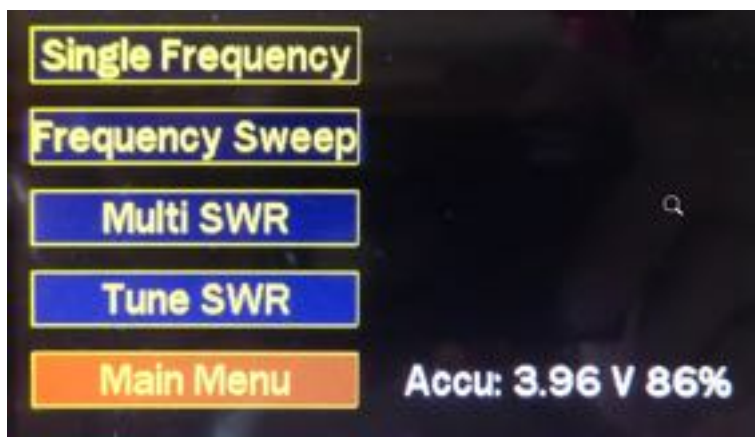

3.1 Single Frequency (Impedance at single frequency)

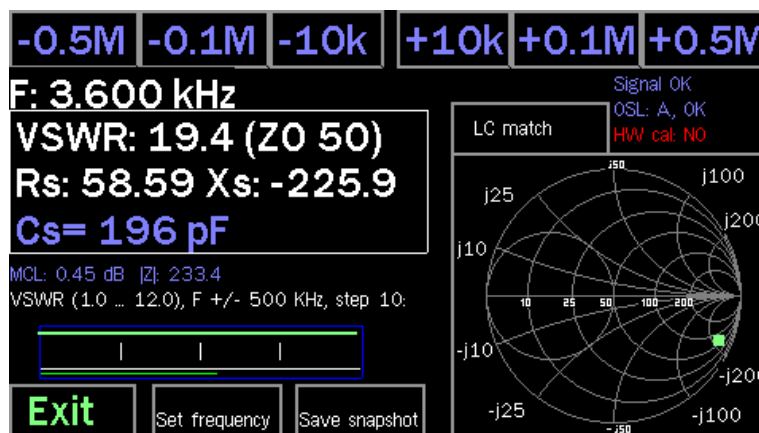

With the buttons at the top of the screen, the frequency can be changed step by step. **Set Frequency** leads to the frequency selection window as in the **Panoramic Scan**.

The outlined area with the SWR Display also contains the values for the equivalent series connection of the measured impedance. Tapping this area switches to the equivalent parallel connection:

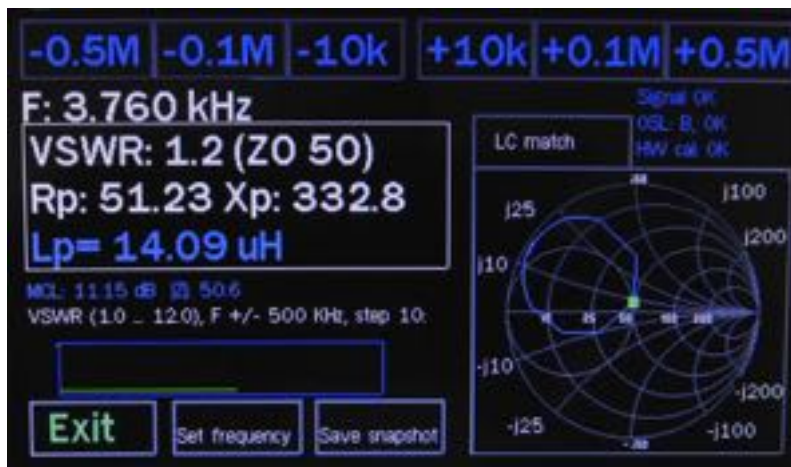

Tapping the **Smith Chart** shows the sizing of the 2 possible LC matching networks to transform the measured impedance to 50 Ω :

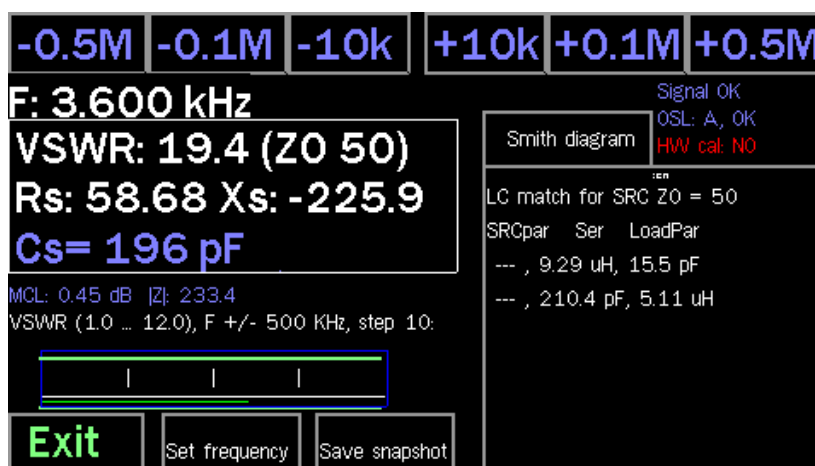

3.2 Frequency Sweep (Panoramic Frequency Scan)

Tapping on the **top of the screen** opens the window for **Frequency Entry**. Optionally, you can select an amateur band or choose the center frequency and bandwidth freely:



With **OK** the frequency input is accepted. **Scan** starts a single sweep, **Auto** activates the continuous fast sweep. By default, the **SWR Chart** is displayed over the selected frequency range. The cursor is at the SWR minimum. It can be moved with the arrows on the left and right edges of the screen. The measured values belonging to the cursor frequency are displayed below the diagram. With the **LOG** button in the upper left corner, the SWR axis can optionally be switched to double logarithmic, which increases the reading accuracy of low SWR values:

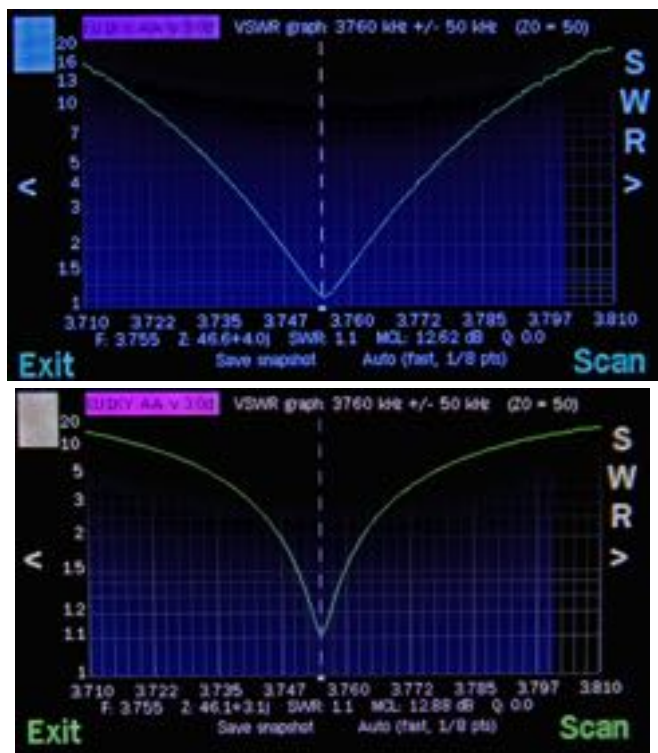

Save snapshot saves the screen content as BMP or PNG, depending on the setting under **Settings > Configuration**. **Exit** returns to the main menu.

By tapping the **middle of the screen**, the display will cycle:

- Real and imaginary components (R / X) of the complex impedance
- Impedance in S11 format (scatter matrix), if activated under **Settings > Configuration**
- Smith Chart
- and back to the SWR history.

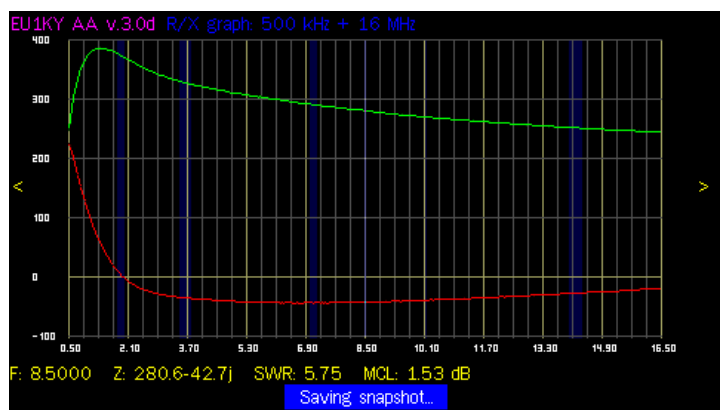

Real and imaginary components (R / X) of the complex impedance

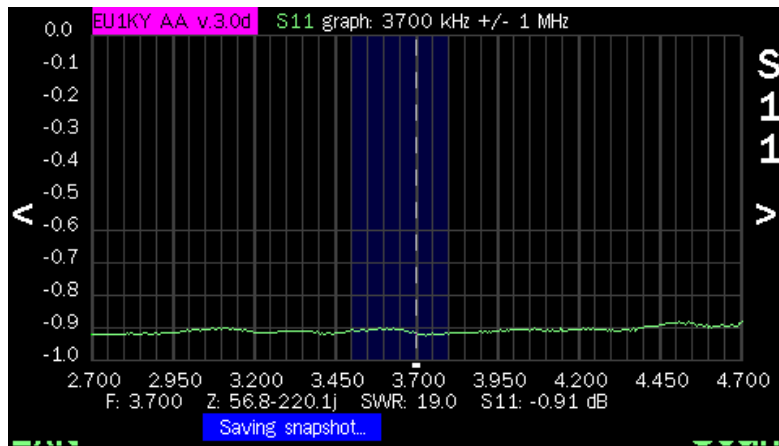

Impedance in S11 format (S parameter matrix)

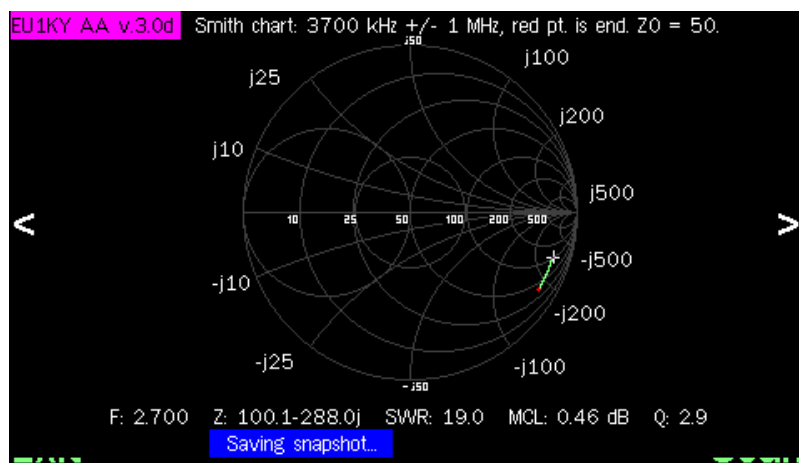

Smith Chart

3.3 Multi SWR

Simultaneous measurement of the SWR on several selected frequency segments.

MHz	SWR	R / X	Exit
3.700	13.7	3 Ohm 2 *j Ohm	+200 k
7.200	8.1	311 Ohm 171 *j Ohm	+200 k
14.200	6.6	141 Ohm 158 *j Ohm	+200 k
21.200	5.2	73 Ohm 109 *j Ohm	+200 k
28.600	4.2	55 Ohm 81 *j Ohm	+1000 k

- To change or add positions: tap the frequency or blank field.
- To delete a position: tap Frequency field and select **Cancel** in the Frequency menu
- The selected frequencies are saved.

3.4 Tune SWR

Measurement and display of the SWR in graphic and acoustic form. The sound is output to pin 1 (D8) of CN7 via a 330Ω resistor to a loudspeaker . SWR measurement changes the color and length of a strip. If the target SWR selected with **SWR_2** or **SWR_3** is undershot, the bar is white and green. If the selected target SWR is exceeded, the bar is white and red. The frequency of the sound varies with the SWR: the smaller the SWR, the lower the tone. **Tone** turns the sound on, **Mute** turns it off.

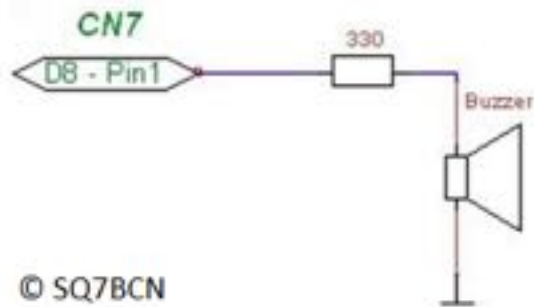
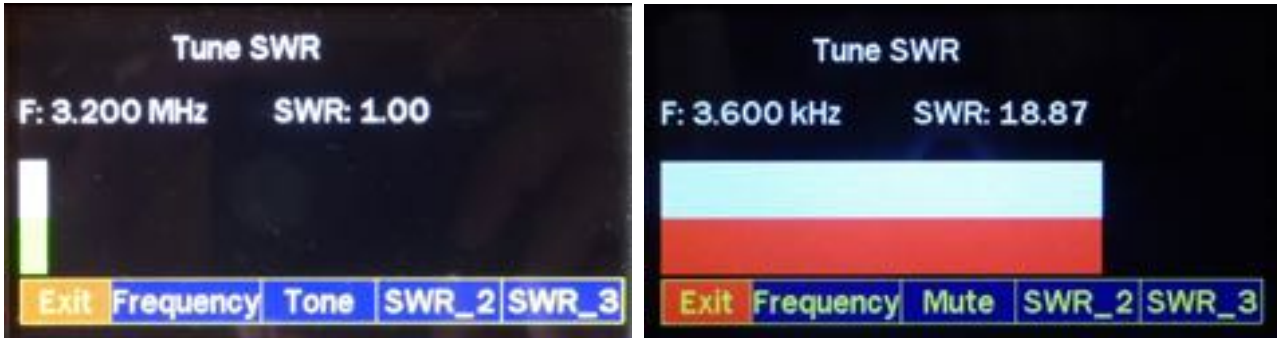

4 Tools

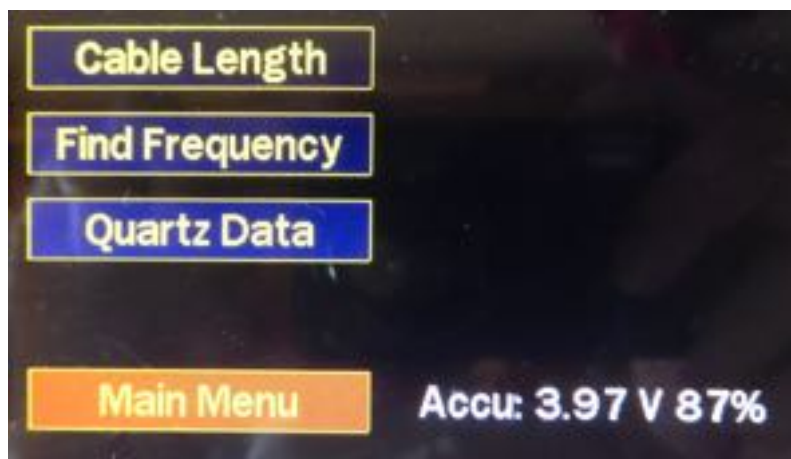

4.1 Cable Length

To determine the electrical length of cables or to locate cable defects. The cursor is automatically at the point of greatest discontinuity. The velocity factor can be changed with **Chf. Vf** be changed. **Store volatile** stores it only for current measurements, **store permanent** against it permanently.

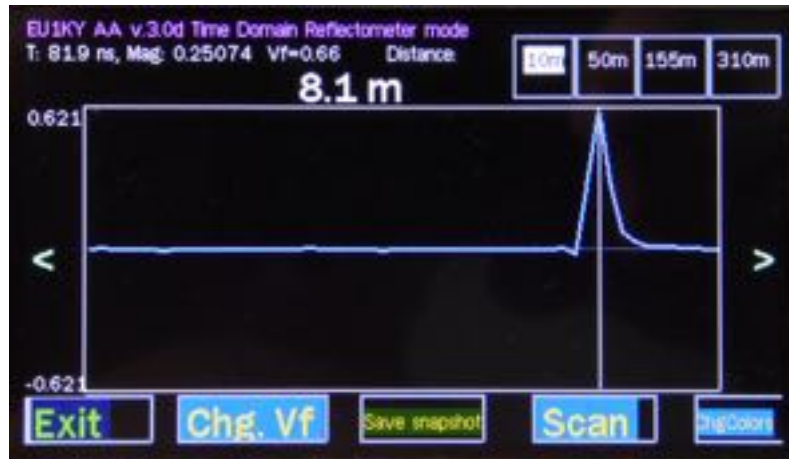

4.2 Find Frequency (Frequency Scanner)

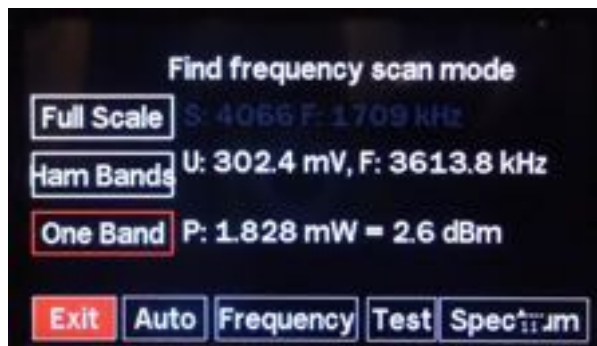

numerischer Modus

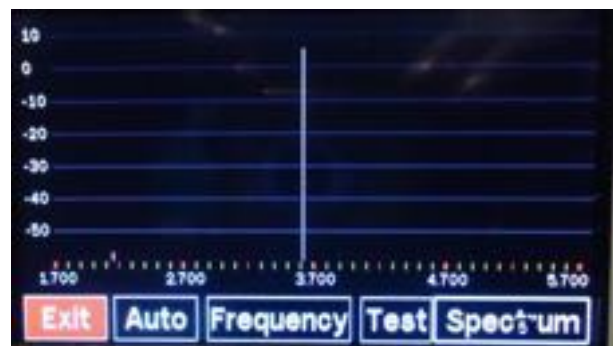

Spektrum-Anzeige

- **Auto** : continuous scanning on / off
- **Frequency** : choice of frequency and scan range
- **Test** : 3.5 MHz generator on / off
- **Spectrum** : spectrum display on / off

4.3 Quartz Data

The implementation corresponds to the method used and published by Melchor Varela EA4FRB.

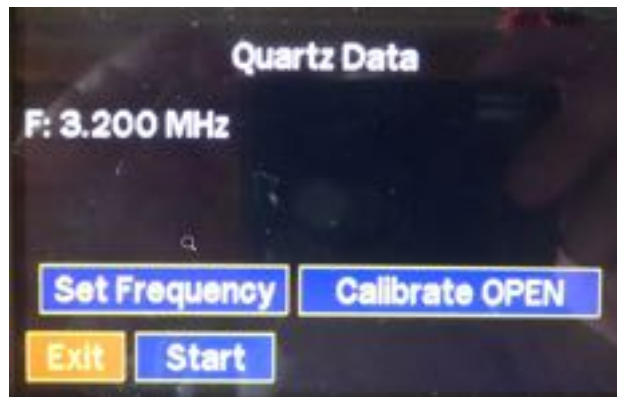

After entering the frequency, **Calibrate OPEN** measures the parasitic impedance of the terminal. Afterwards, the user is asked to put the quartz in the socket and to start the measurement with **Start**.

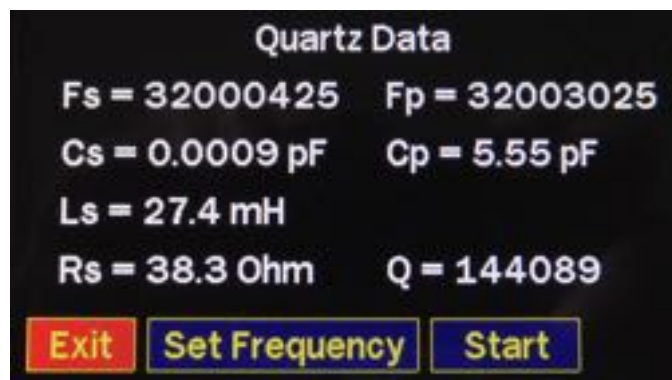

5 Generator

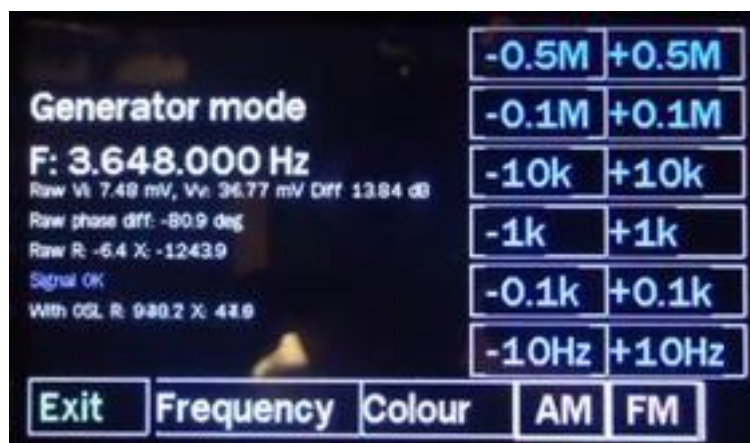

- **Colour** changes the screen colors
- **AM** modulates the carrier at 500Hz
- **FM** effects a frequency shift keying of ± 150 Hz at 500 Hz

6 Parameters (device and calibration)



6.1 Colours / Beep

Here, the screen display can be adapted to different environments. If a loudspeaker according to 3.4 is available, a keyboard acknowledgment tone can be selected here.

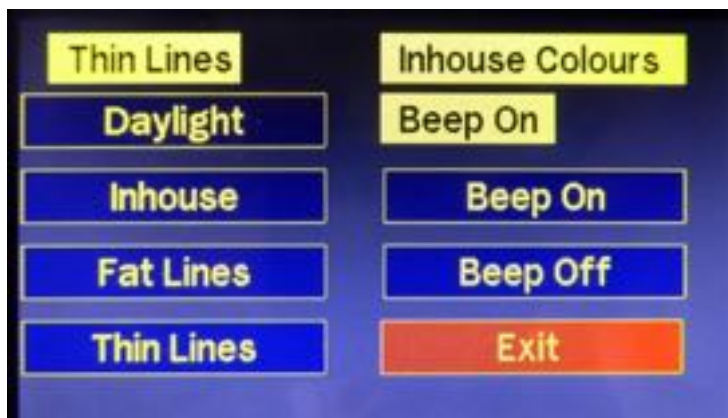

6.2 Configuration

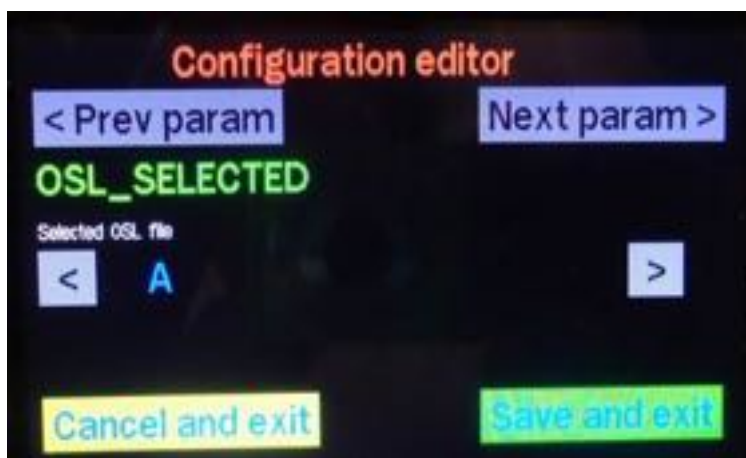

In normal operation, these parameters hardly ever need to be changed. The following list is not complete.

Name	Bedeutung
OSL_SELECTED	File in which the results of the OSL calibration are saved
Z0	Reference impedance for SWR and Smith chart
OSL_RLOAD	Resistance value for the nominal impedance
OSL_RSHORT	Resistance value for the short circuit
OSL_ROPEN	Resistance value for the open circuit
MEAS_NSCANS	Number of scans in Measurement mode
PAN_NSCANS	Number of scans in Panoramic scan
PAN_CENTER_F	Panoramic scan: Choice between start or center frequency
LOW POWER TIMER	Time until the screen turns to dark
S11_SHOW	Panoramic scan: Display S11 yes / no
SCREENSHOT_FORMAT	Screenshot Format : BMP or PNG
TDR_VF	Cable velocity factor for measurements in the time domain
SHOW_HIDDEN	Show hidden parameters yes / no

6.3 Calibration

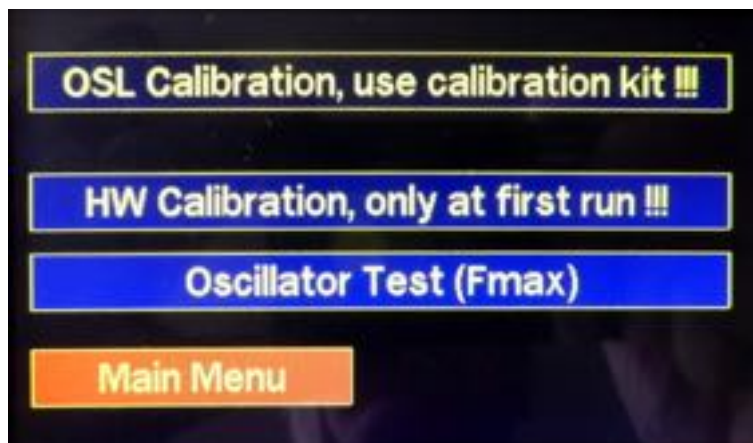

6.3.1 OSL Calibration

The OSL requires test resistors: 0 Ω (short circuit), 50 Ω (reference impedance), open connector (open circuit). Under **Settings > Configuration > Z0** you can select 75, 100 or 150 Ω as reference impedance in addition to 50 Ω .

6.3.2 HW Calibration

- not required while using the device.
- Before the HW calibration on the adapter PCB, set the jumper to the **CAL** position.
- After the HW calibration on the adapter PCB, set the jumper to the position **WORK**.

6.3.3 Oscillator Test (Fmax)

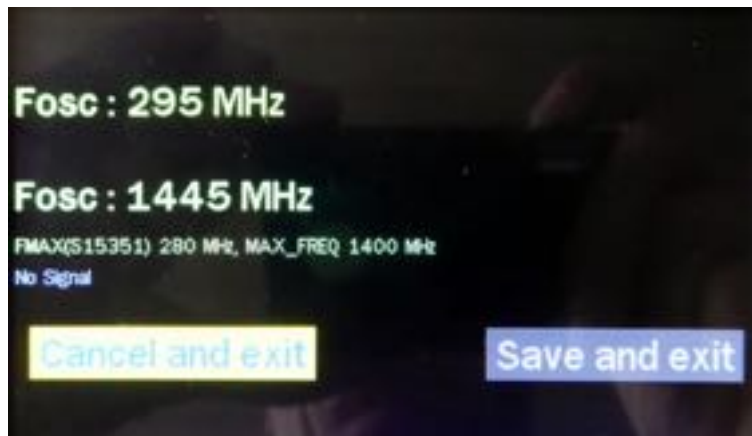

Like most components , the SI5351 generator works beyond the specified limits. The software has been extended so that the 5th harmonic can also be used . Here , the maximum frequency of the SI5351 and its 5th harmonic is determined iteratively . As a result, two values (FMAX (SI5351) and MAX_FREQ) are output , which are defined in the configuration menu (see 6.2).

6.4 DSP

Indicates the noise level at the input of the controller board.

6.5 Accu Settings

A prerequisite for displaying the battery voltage is a hardware extension: From the positive battery connection behind the protection circuit (red wire from the battery holder to the small PCB with the charging electronics) and behind the power switch, a voltage divider with 2 x 10 k Ω must be connected to ground. Its center is connected to pin 4 of CN5 on the adapter PCB. CN 5 pin 4 is also called A3 or PF8 and leads to the ADC3_IN6 input of the CPU. If you do not want to make this extension, you can deactivate the display of the battery voltage with **Voltage Display Off**.

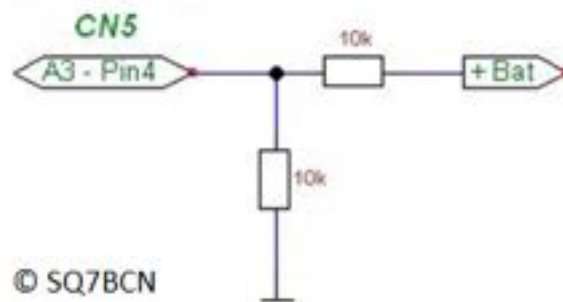

The values **MaxV** and **MinV** are required to determine the percentage display. MaxV corresponds to 100 %, MinV 0 %. Since most battery technologies have a very non-linear discharge curve (capacitance vs. voltage), the percent display is only an indication of the approximate remaining capacity.



6.6 Date / Time

Prerequisite for the display of date and time is the installation of a clock module (RTC) with the IC DS 3231 and serial I2C communication.

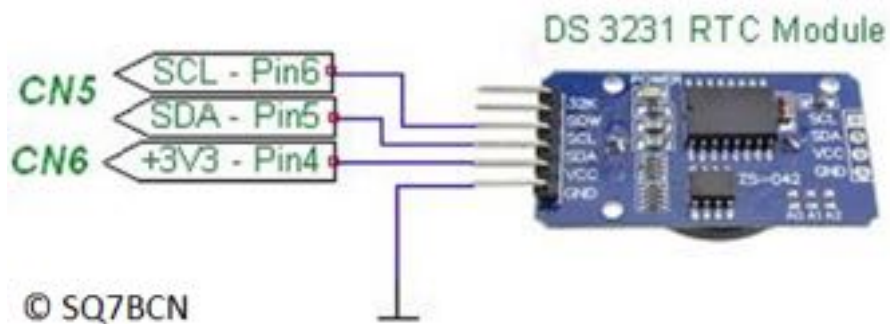

The first input is the date in the format YYYYMMDD, followed by the time in the format hhmm:

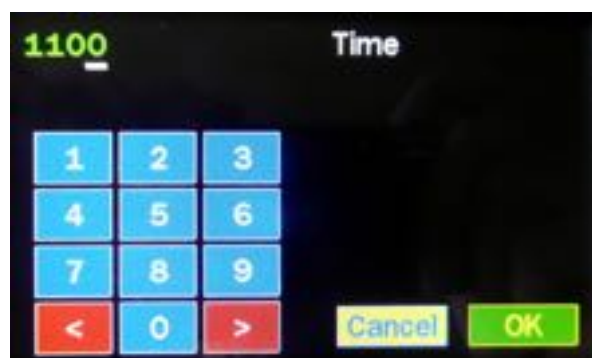

The time is displayed in the main menu (see section 2). The saved screenshots get a time stamp (see 7.1).

7 Data / PC

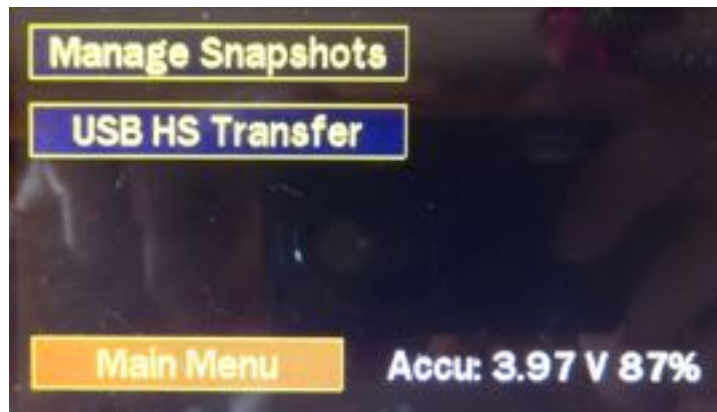

7.1 Manage Snapshots (display and delete screenshots)

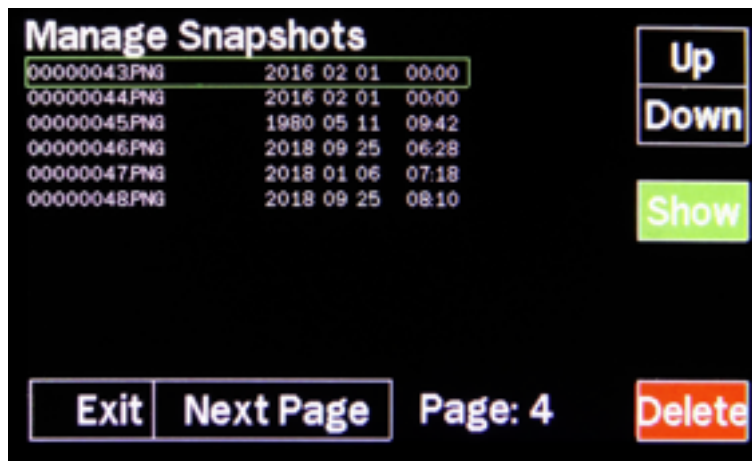

7.2 USB HS Transfer (data exchange with the PC)

The computer is connected to the UBS-HS USB port.



The device appears as a drive and has a directory structure as shown in the following screenshot:

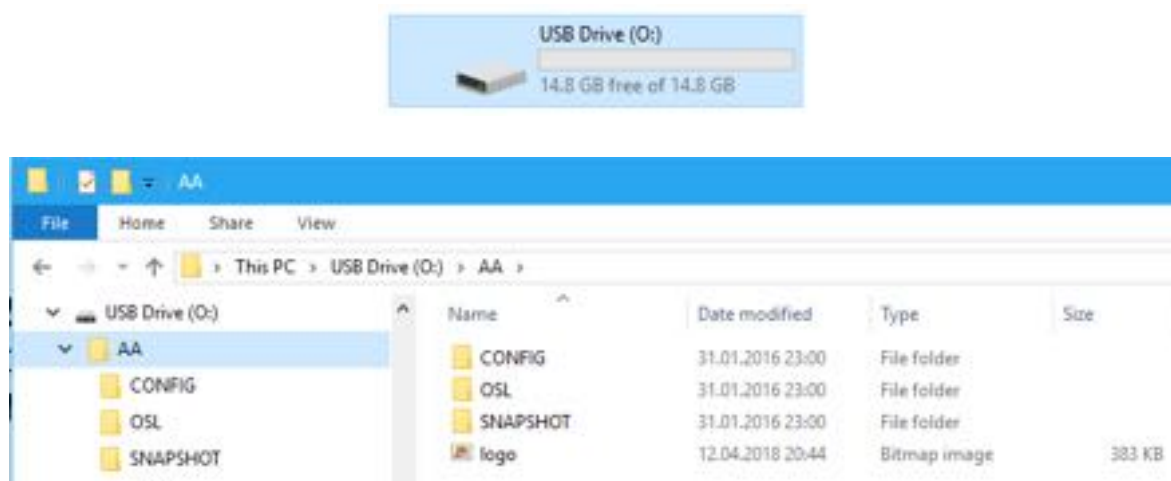

The **SNAPSHOT** directory contains the stored measurement results. These are available in 2 formats:

- As image (BMP or PNG depending on parameter **SCREENSHOT_FORMAT** under **Settings > Configuration**)
- As numeric data in **Touchstone** Format:

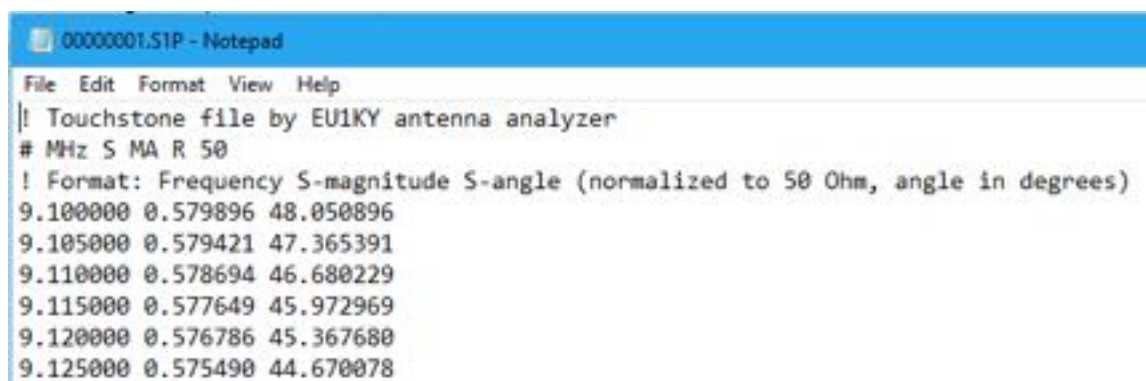

8 Custom Splash Screen



A BMP or PNG file of the size 480 x 272 and the name **logo.bmp** respectively **logo.png** is stored in the directory AA. To do this, connect the device to the PC as described in section **USB HS Transfer**.

9 Firmware update

The latest version of the extended firmware can be found on the website of Wolfgang DH1AKF: <http://www.wkiefel.de/x28/test/F7Discovery.bin>

The easiest way to program is using " drag-and-drop":

- Turn on device
- Connect the USB connection **ST-Link** to the PC
- In File Explorer, a new drive named **DIS_F746NG** appears:

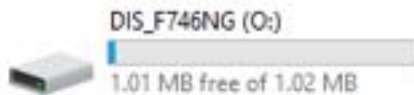

- **Drag** or **copy** the firmware (link above) to the new drive
- The device recognizes the new firmware, automatically loads it into flash memory and then initiate Reboot. The " build timestamp" of the firmware is displayed in the main menu at the bottom of the screen:

EU1KY AA v.3.0d, mod. DH1AKF, Build: 2018-10-20 14:34 UT

Alternatively, programming can also be performed using the [STM32 ST-LINK Utility](#) from [ST Microelectronics](#) on the **ST-Link** USB port.

- **Target > Connect** : Connect: connect to the device
- **File > Open File...** : load firmware in binary form
- **Target > Program & Verify** : program and verify

10 Software «AntScope»

In the main menu, the device can be remotely controlled via the USB connection **ST-Link** with the software **AntScope**. The measurement results are also available in numerical form and can be used for further calculations or simulations.

Before operating with AntScope , the driver for the STM32 Disco card must be installed. First select the COM port in the AntScope program and select the option **AA-600 Analyzer (RigExpert)** as the measuring device.

11 Software conversion from EU1KY to DH1AKF

After the conversion from the original EU1KY software to the extended version of DH1AKF described here, a complete calibration (hardware calibration according to 6.3.2 and OSL calibration according to 6.3.1) is mandatory. If problems occur during calibration, reformatting the SD card with a PC will help. The reason for this is the changed data structure. Afterwards the complete calibration has to be carried out again.

This manual was wrtitten by::

Justas (LY2BOK), Wolfgang (DH1AKF) and Markus (HB9BRJ). English translation François (F4HTX).

Date: 16.04.2019

Firmware: EU1KY AA v.3.0d, mod. DH1AKF, Build: 2019-03-20 21:08 UT